

TIMO

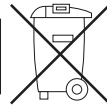

VERSION: 01-01/2018

LEFT • GAUCHE • SINISTRA • LINKS •
 ESQUERDA • IZQUIERDA • LIJEVO • SOL • LEWY

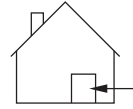
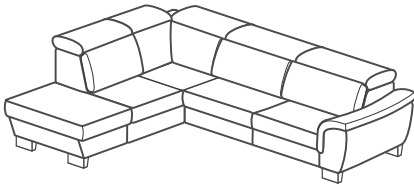

RIGHT • DROIT • DESTRA • RECHT • DIREITO •
 DERECHO • PRAVO • SAĞ • PRAWY

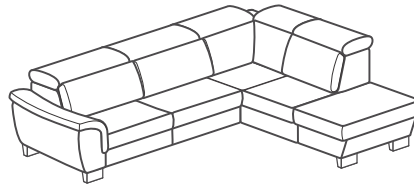

15min

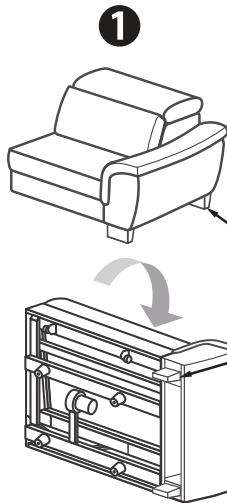

1

SAV ID LABEL

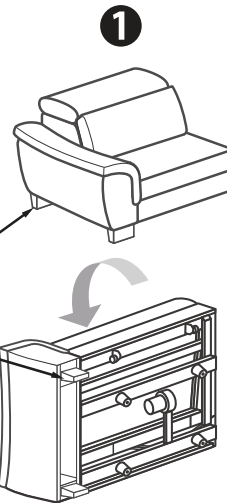

1

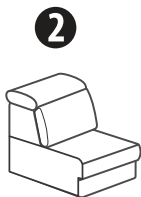

2



2

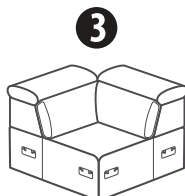

3

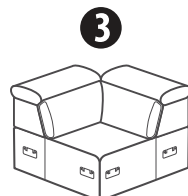

3

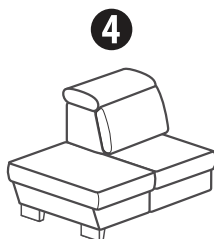

4

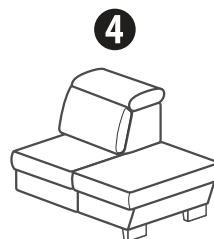

4

Attention ! Pour toute réclamation veuillez bien garder l'étiquette SAV collée au- dessous du meuble
Attenzione! Per favore conservate l'etichetta presente su ogni componente per eventuali reclami
 Achtung! Unter dem Moebel befindet sich ein Etikett. Bitte bewahren das Etikett auf eine mögliche Reklamation
Attention! There is a label under every piece of furniture. Please keep it for possible complaints

Atención! Existe una etiqueta debajo de cada mueble. Por favor, quédensela para posibles futuras quejas
Atenção! Abaixo do móvel se encontra uma etiqueta. Por favor não remova esta e mantem a etiqueta para qualquer reclamação
 Važno! Svaki proizvod ima svoju najljepnicu na dnu. Molimo vas da ju sačuvate za eventualne reklamacije
Dikkat önemli !

Bu etiketi lütfen çıkartmayınız. İleride oluşabilecek bir problem için saklayınız.

Bu bilgi bize problemin hızlı çözülmesi için gerekli olacaktır

Uwaga! Na spodzie mebla umieszczona jest etykieta. Prosimy ją zachować na wypadek reklamacji.

AVANT DE COMMENCER, SE REPORTER AUX CONSEILS DE MONTAGE EN ANNEXE
BEFORE STARTING, REFER TO THE ASSEMBLING ADVICE IN ANNEX
 PRIMA DI COMINCIARE VERIFICATE LE ISTRUZIONI DI MONTAGGIO
VOR DER MONTAGE, BITTE BEILIEGENDEN ANWEISUNGEN FOLGEN
 ANTES DE COMEÇAR, ADIARSE AOS CONSELHOS DE MONTAGEM EM ANEXO
ANTES DE EMPEZAR CONSULTE LOS CONSEJOS PARA EL MONTAJE

PRIJE POČETKA MONTAŽE MOLIMO PAŽLJIVO PROČITAJTE UPUTE ZA MONTAŽU
BASLAMADAN ÖNCE EKTEKI KURULUM TALIMATLARINI OKUYUNUZ.
 PRZED MONTAŻEM PROSZĘ O ZAPOZNANIE SIĘ Z ZAŁĄCZONĄ INSTRUKCJĄ MONTAŻU.

TIMO

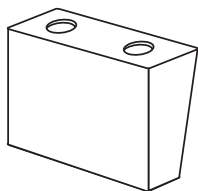

5x

A

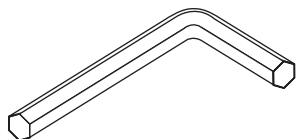

1x

B

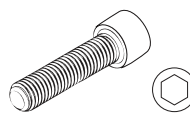

10x

C

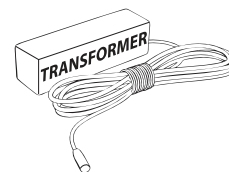

1x

D

1

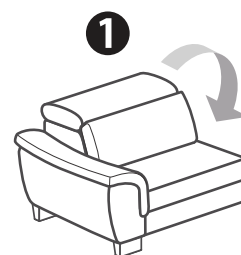
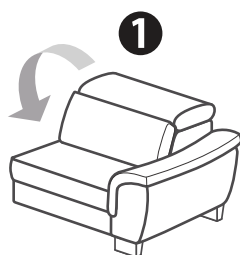

2

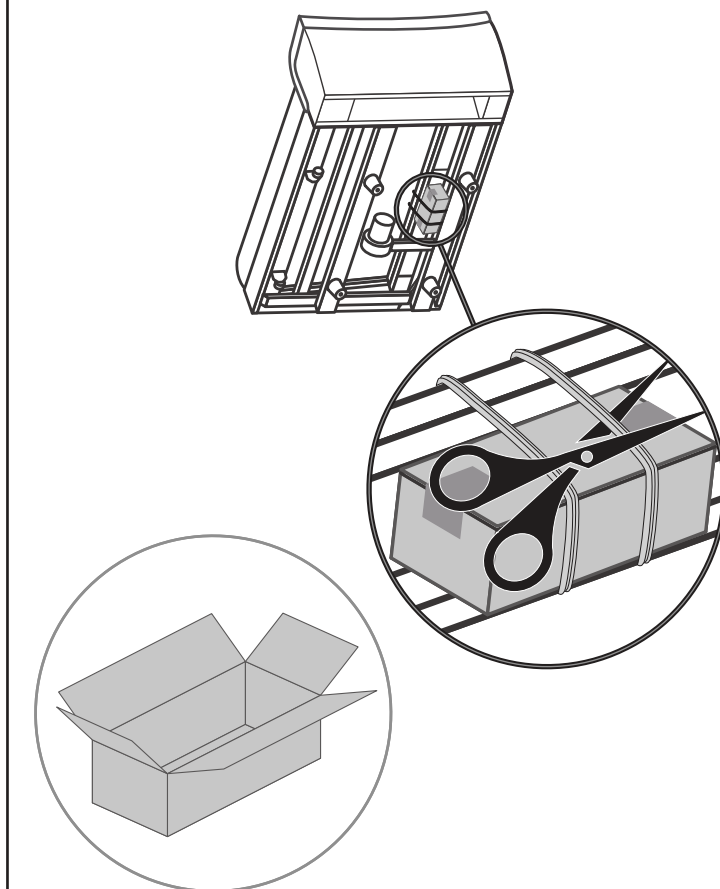
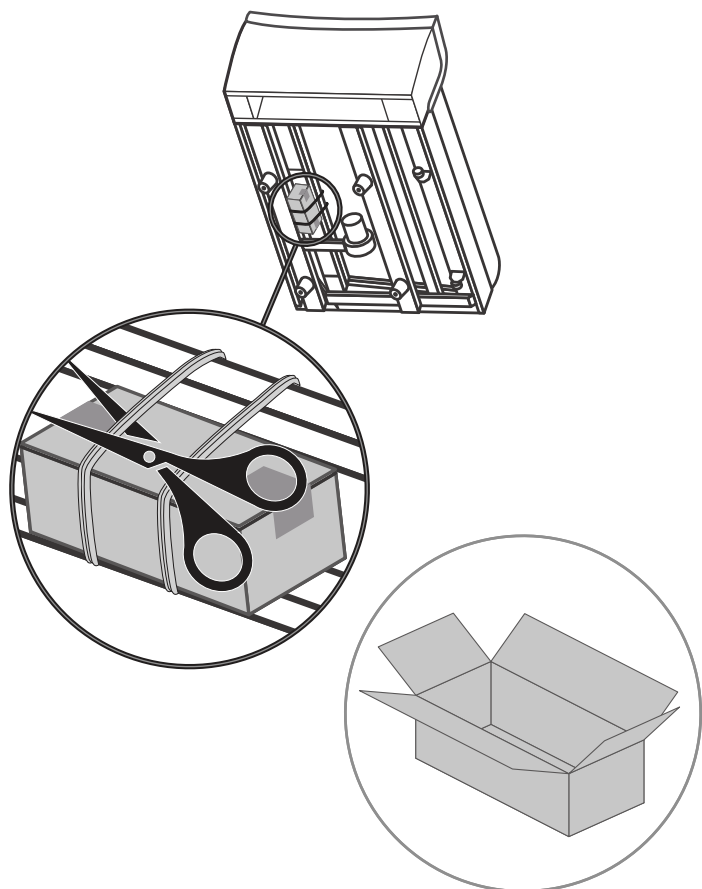

TIMO



3

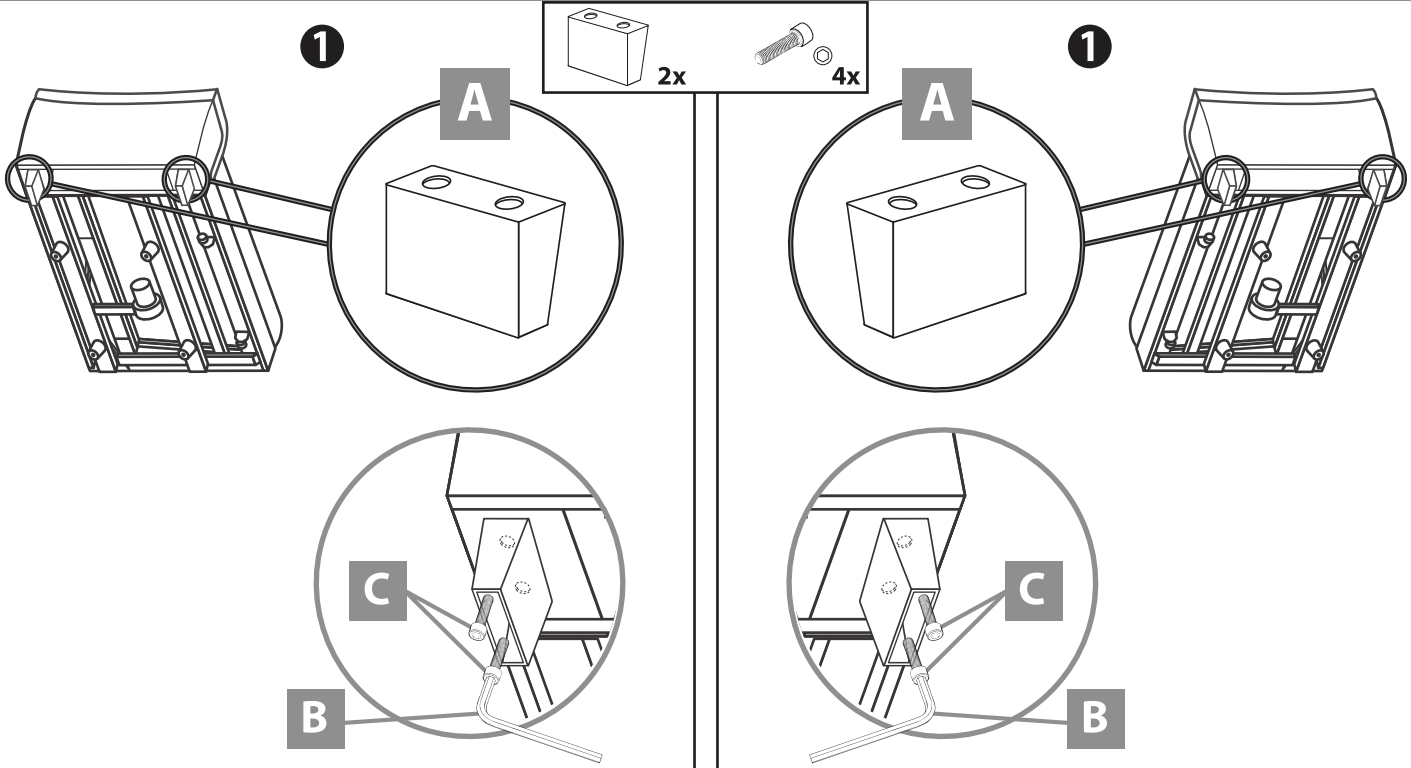

4

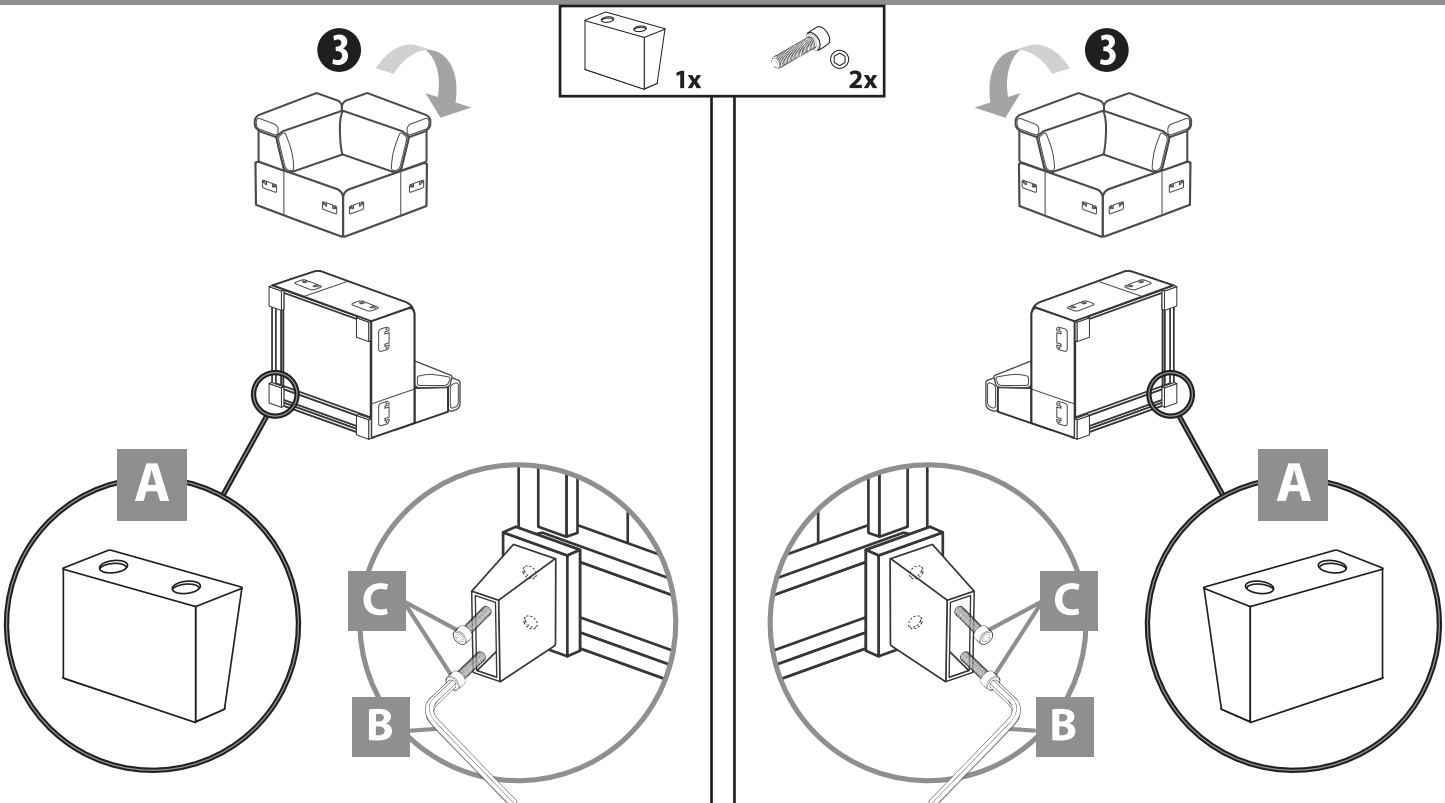

TIMO



5

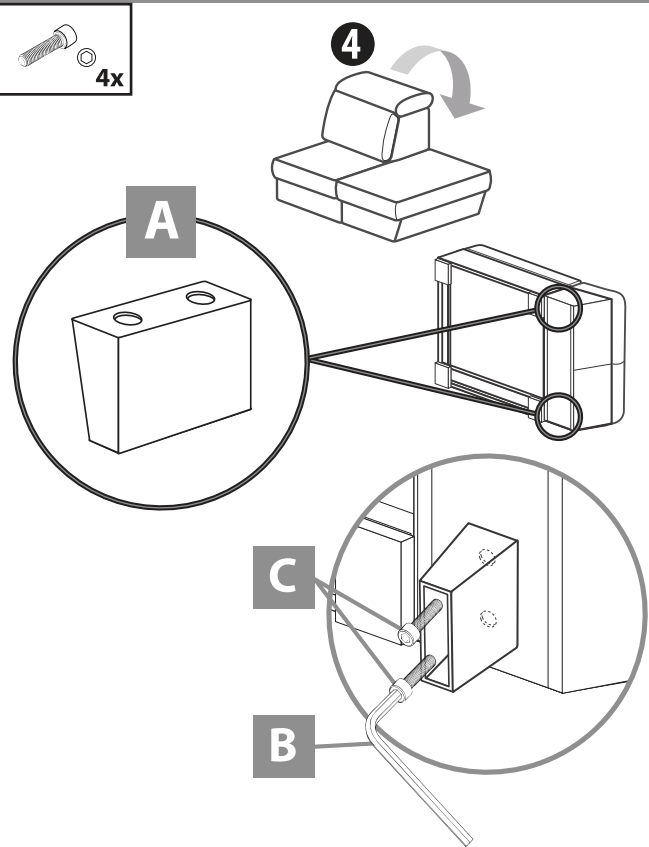
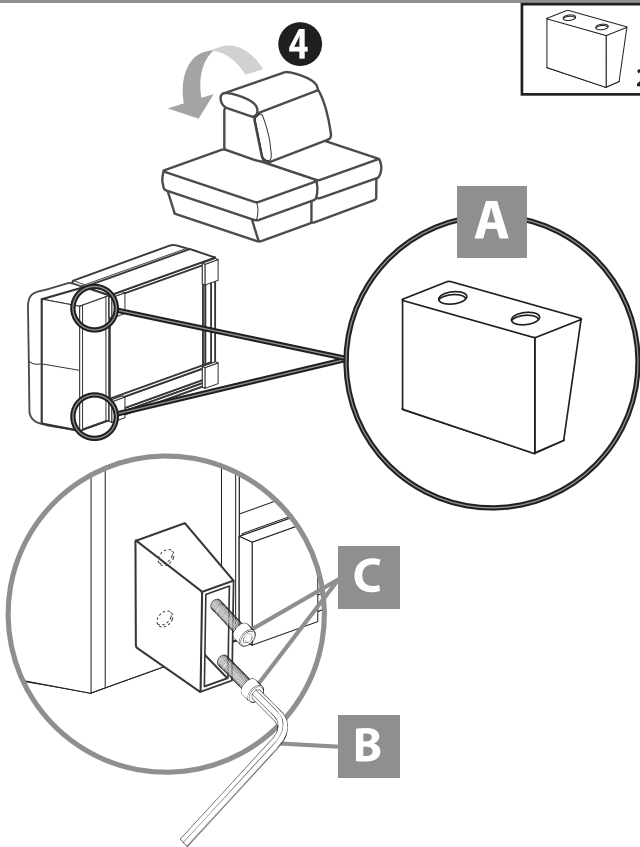

6

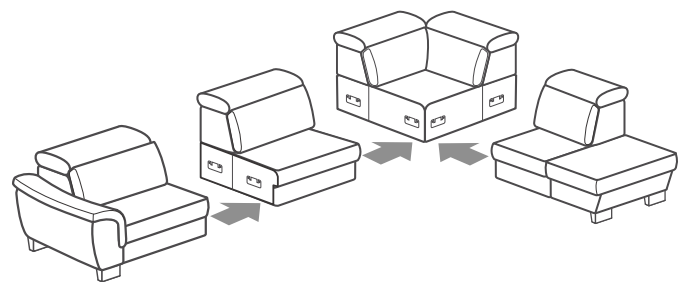
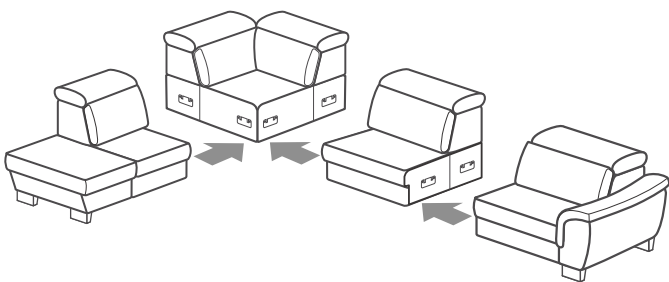

7

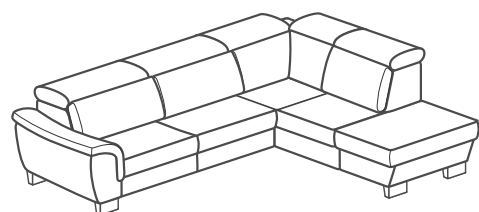
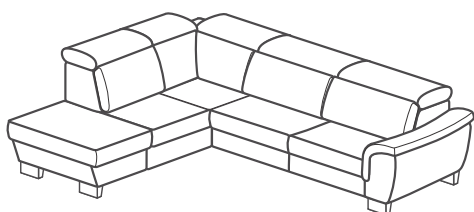

TIMO



8

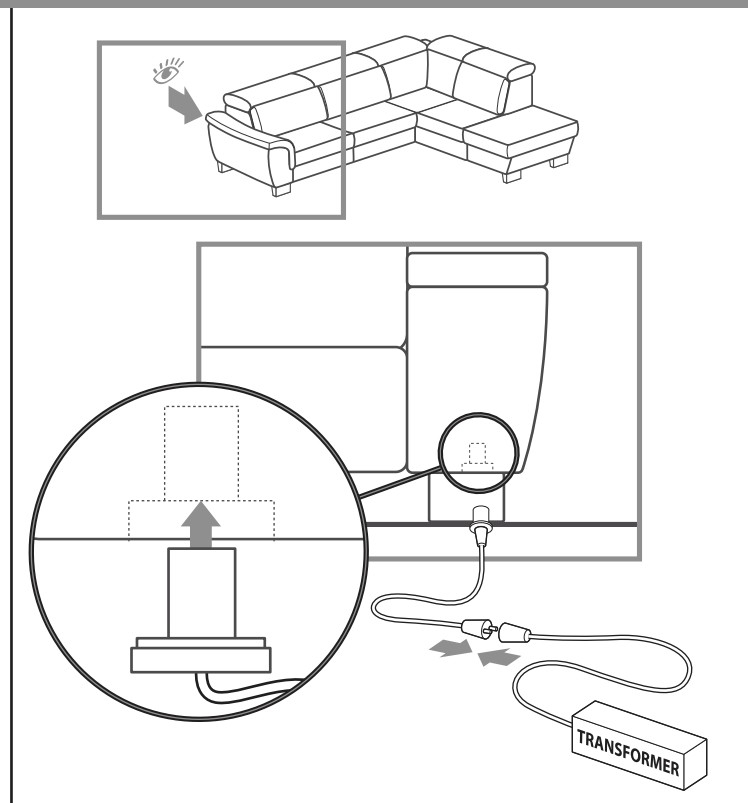
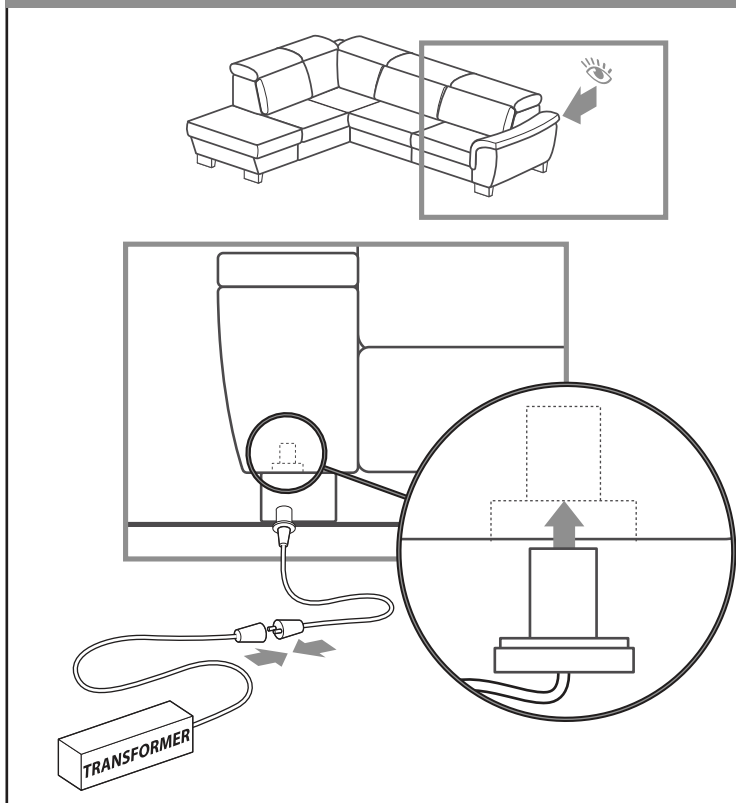

9

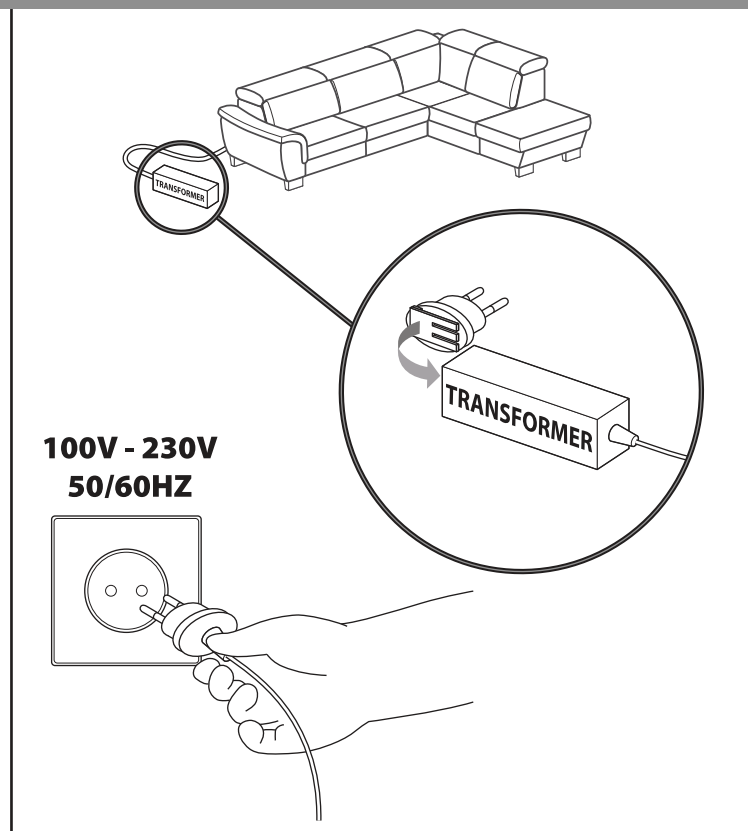
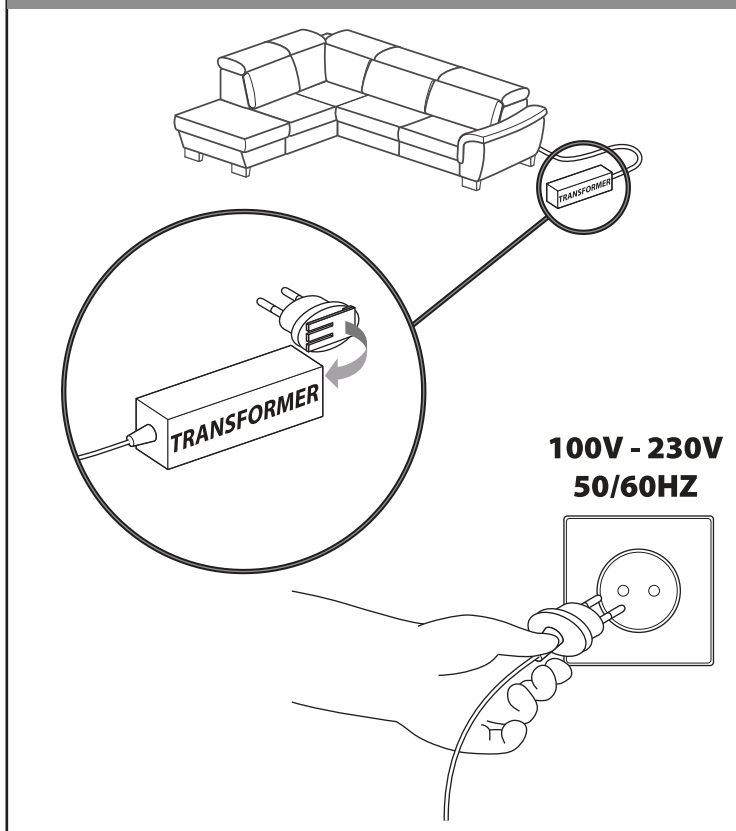

TIMO



10

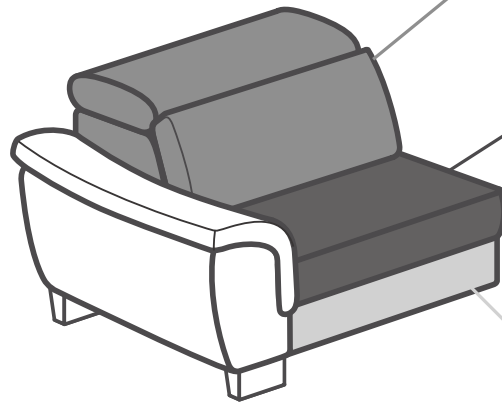
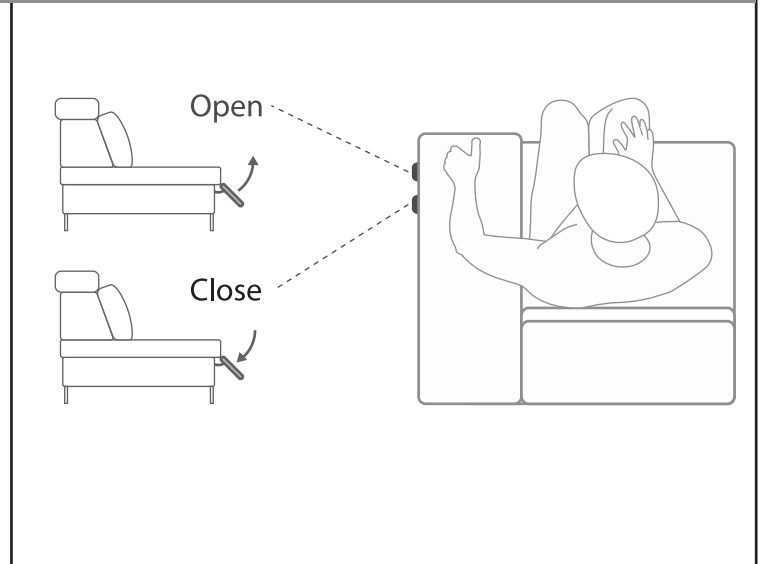
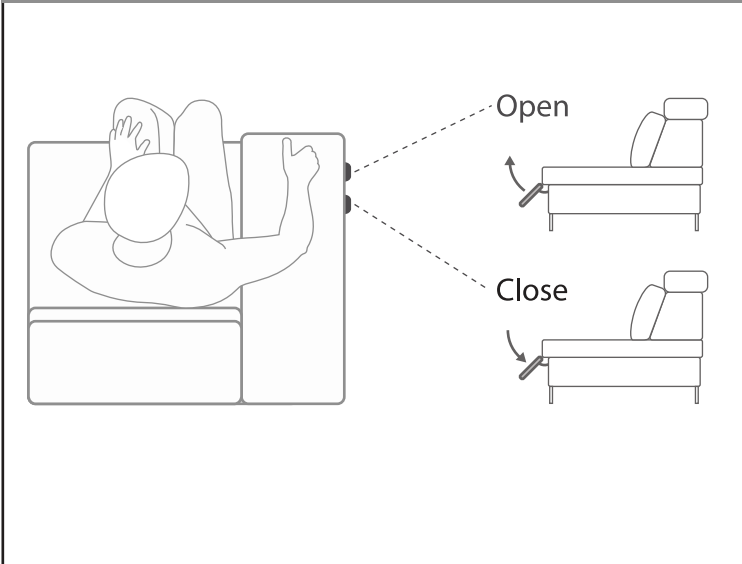

40kg

90kg

20kg



AC/DC Adapter
 Model No.: KE 1110030/MO-PS-1589
 Input: 100-240V~, 50/60 Hz, 1.5A
 Output: DC29V --- 1A
 Ta=40°C 70.2016 \ominus — \oplus
 Duty Cycle: 2min on/18min off
 Current Fuse: T2AL250VAC
 For indoor use only IP20
 Class 2 Power Unit
 Efficiency level $\text{\textcircled{V}}$
 GEMS \checkmark CEC \checkmark ERP \checkmark
 SELV \checkmark RoHS \checkmark REACH \checkmark

WARNING:

Accessible cables, electrical wires & cords present a risk of strangulation for the young children. These accessible elements should always be kept out of reach of young children.

ATTENTION:

Les cables, fils électriques cordes accessibles présentent un risque d'étranglement pour les jeunes enfants. Ces éléments accessibles doivent toujours être tenus hors de portée des jeunes enfants.

WARNING

- HU** Ez a modell egy hosszú és megerőltető utazás. Használat el. ráuuk fel, és érintse meg n. a pad megbirkózni Ez látszatát kelti elegancia és vonzerejét.
- POR** Este modelo tem uma viagem longa e extenuante. Antes de usá-lo, apertar e toque no teclado de lidar Isto dá a aparência de elegância e atratividade.
- FRA** Ce salon vient de faire un long voyages. Pour plus d'élégance et de volume, nous vous conseillons de secouer et de taper les coussins avec la main.
- ITA** Questo salotto ha appena fatto lunghi viaggi. Per più eleganza e volume, vi consigliamo di scuotere e battere i cuscini.
- SPA** La sofa en el salyn es destina para descansar. Nosotros les recomendamos los cojinos para el aspecto más elegante.
- GB** This sofa has just made a long trip. For more elegance and volume, we advise you to shake and tap the cushions with your hand.
- DE** Dieses Sofa hat gerade eine lange Reise gemacht. Für mehr Eleganz und Volumen empfehlen wir Ihnen, die Kissen mit der Hand zu schütteln und zu klopfen.
- PL** Państwa sofa ma za sobą długą podróż. Proszę dobrze wygładzić rękoma poduszki w celu uzyskania odpowiedniego kształtu i objętości mebla.

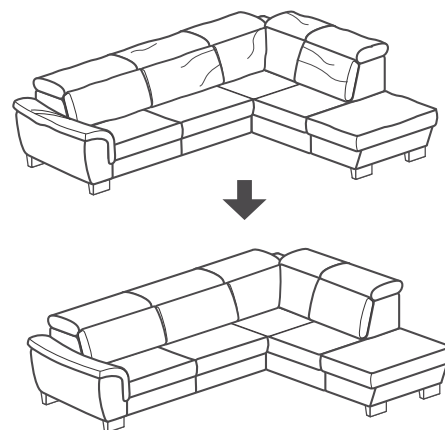

- HU** Minden egyes használat után, kérem tegye le a párnák.
- POR** Após cada uso, por favor, colocar para baixo as almofadas.
- FRA** Renouveler ce procédé après chaque utilisation.
- ITA** Ciò procedere, deve essere rinnovare dopo ogni utilizzo.
- SPA** Despues cada uso hay que arreglar los cojinos.
- GB** Repeat this after every usage.
- DE** Wiederholen Sie dies nach jeder Verwendung.
- PL** Czynność tą należy regularnie powtarzać.

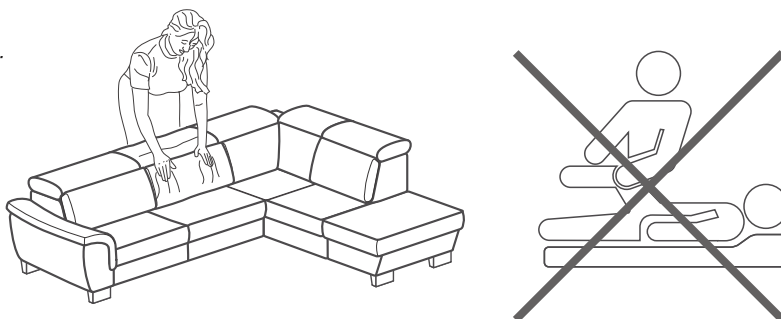

WARNING: Do not use this seat for people suffering of a physical handicap, and needing a seated continue and frequent position.
-WARNING: This product shall be used in a frame of leisure or relaxation. This product does not comply with the norms in force for medical material.

ATTENTION: Ne pas utiliser ce siège pour des personnes souffrant d'un handicap physique et nécessitant la position assise continue et fréquente.
ATTENTION : Ce siège ne doit être utilisé que dans le cadre du loisir ou de la relaxation. Ce siège ne répond pas aux normes en vigueur du matériel médical.

WARNING: This appliance can be used by children aged from 8 years and above and persons with reduced physical, sensory or mental capabilities or lack of experience and knowledge if they have been given supervision or instruction concerning use of the appliance in a safe way and understand the hazards involved. Children shall not play with the appliance. Cleaning and user maintenance shall not be made by children without supervision.

ATTENTION: Cet appareil peut être utilisé par des enfants âgés d'au moins 8 ans et par des personnes ayant des capacités physiques, sensorielles ou mentales réduites ou dénuées d'expérience ou de connaissance, s'ils (si elles) sont correctement surveillé(e)s ou si des instructions relatives à l'utilisation de l'appareil en toute sécurité leur ont été données et si les risques encourus ont été appréhendés. Les enfants ne doivent pas jouer avec l'appareil. Le nettoyage et l'entretien par l'usager ne doivent pas être effectués par des enfants sans surveillance.

ACHTUNG: Dieses Gerät kann von Kindern ab dem Alter von 8 Jahren und Personen mit eingeschränkten physischen, sensorischen oder geistigen Fähigkeiten oder mangelnder Erfahrung und Kenntnissen verwendet werden, nur wenn sie die Aufsicht über den sicheren Umgang mit dem Gerät erhalten und die Gefahren verstanden haben. Kinder dürfen nicht mit dem Gerät spielen. Reinigung und Instandhaltung dürfen nicht von Kindern ohne Aufsicht durchgeführt werden.

UWAGA: Urządzenie to może być używane przez dzieci w wieku powyżej 8 lat. Osoby z ograniczonymi możliwościami fizycznymi, sensorycznymi lub umysłowymi jak również osoby bez doświadczenia i wiedzy mogą używać urządzenie jedynie pod nadzorem i po wcześniejszym zapoznaniu się z działaniem oraz zagrożeniami wynikającymi z użytkowania urządzenia. Dzieci nie mogą bawić się urządzeniem. Czyszczenie i konserwacja nie mogą być wykonywane przez dzieci bez nadzoru.

